

COOL BOOST WATER METHANOL SYSTEMS SNS STAGE 2 V2 PROGRESSIVE WIRING SCHEMATIC GENERIC



REFER TO BOOST SOURCE NOTES

FOR BOOST BASED CONTROLLERS ONLY

REFER TO AUXILIARY OUTPUT NOTES

- AUXILIARY OUTPUT
 - BOOST SAFE (RELAY FOR CIRCUIT CUT)
 - SYSTEM STATUS LED (MIMIC)

REFER TO AUXILIARY INPUT NOTES

- AUXILIARY INPUT
 - VOLTAGE INPUT (MAF/ TPS/ MAP INPUT)
 - CLUTCH INPUT (SYSTEM PAUSE DURING GEARSHIFTS)

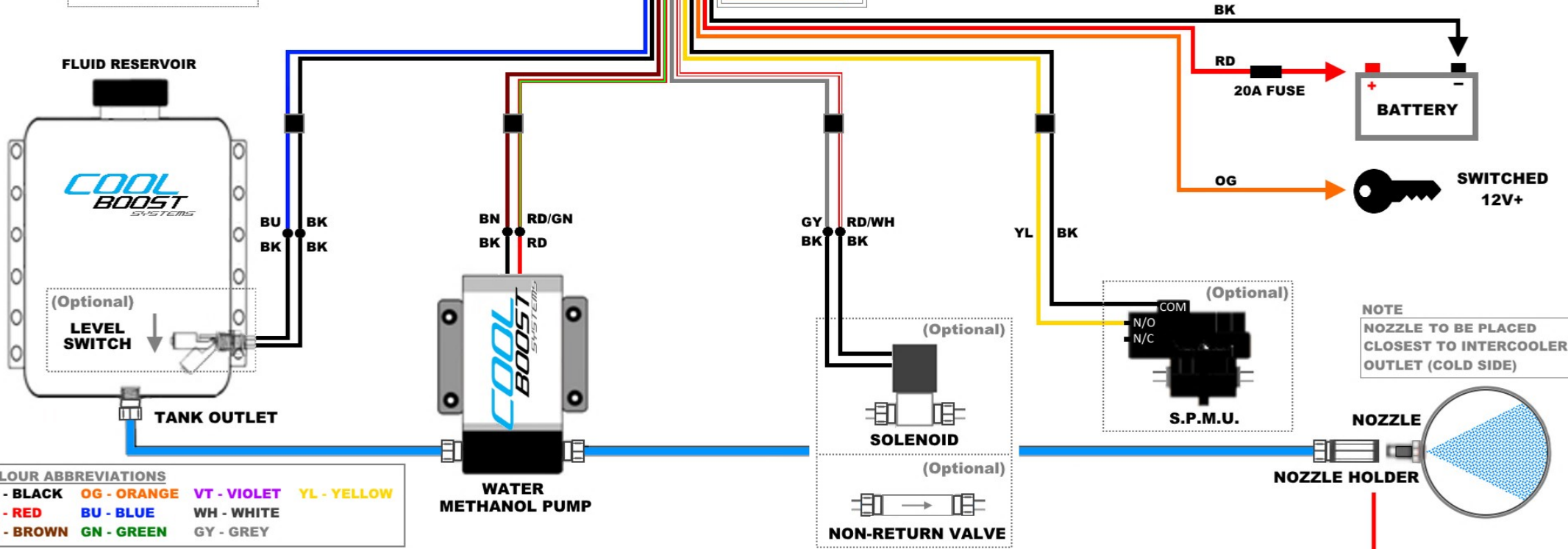

COLOUR ABBREVIATIONS

BK - BLACK	OG - ORANGE	VT - VIOLET	YL - YELLOW
RD - RED	BU - BLUE	WH - WHITE	
BN - BROWN	GN - GREEN	GY - GREY	

IMPORTANT INSTALLER INFORMATION

IF THE SYSTEM IS NOT EQUIPPED WITH A SOLENOID, INDIVIDUALLY TAPE UP AND ISOLATE THE GREY & RED/ WHITE WIRES
 IF THE SYSTEM IS NOT EQUIPPED WITH A LEVEL SWITCH, CONNECT THE BLUE WIRE TO ITS PAIRED BLACK WIRE
 IF THE SYSTEM IS NOT EQUIPPED WITH A SPMU, CONNECT THE YELLOW WIRE TO ITS PAIRED BLACK WIRE
 IF THE AUXILIARY OUTPUT IS NOT UTILIZED, INDIVIDUALLY TAPE UP AND ISOLATE THE ORANGE & GREEN WIRES
 IF THE AUXILIARY INPUT IS NOT UTILIZED, TAPE UP AND ISOLATE THE WHITE WIRE

NOTE
 NOZZLE TO BE PLACED CLOSEST TO INTERCOOLER OUTLET (COLD SIDE)

..... 30CM MAX